

WINNERS ONLY[®] Assembly Instructions

PROD . NO: **DBFT145024**

Thank you for purchasing this quality product. Please read the instructions thoroughly before unpacking the assembly parts.
Caution: Sharp exposed staple tips can cause injury, therefore for your protection, please remove any exposed staples used in packing.

Please keep all hardware parts out of the reach of children.

1. We recommend that you should assemble this product with the assistance of another person: this will make the assembly easier, and will help to prevent personal injury and to insure parts are not damaged during the assembly process.
2. Before beginning, please check the packing materials carefully for small parts which may have come loose inside the carton during shipping. Please do not discard any packing material until all parts have been located. If any parts are missing, please contact your dealer for prompt replacement.
3. To prevent damage to your floor or carpet, please check the bottom of each piece of furniture for stain residues and rough surfaces and also check for staples or nails left after removing the packing materials. The manufacturer will not be held responsible if preventive steps are not taken prior to installation.
4. Please do not over tighten screws or bolts. During normal use everyday, screws, bolts, nuts and wooden plugs may loosen up. They should be periodically inspected and re-tightened to prevent damage to the furniture and (or) personal property of cause injury. Always check to be sure all hardware on this list and the below mentioned components are attached to the furniture properly and kept tightened.
5. Please lay all parts and hardware on a non abrasive surface such as a carpet, and follow the assembly.

This product will take 15-20 minutes to assemble.







Reminders

1. Use only the hardware supplied.
2. Once the product is assembled, level and tighten all the bolts.
3. Do not over-tighten bolts.
4. This item may require periodic tightening





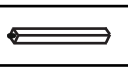

NOTE:

1. Two or more people are needed for assembly
2. Please keep all hardware parts out of the reach of children.

COMPONENT LIST: DBFT145024

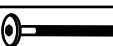
| NO | DESCRIPTION | SKETCH | QTY |
|----|---------------------------|---|-------|
| A | Hardware Bag |  | 1 pce |
| B | Chair Back |  | 1 pce |
| C | Wood Seat |  | 1 pce |
| D | Front Leg (Right) |  | 1 pce |
| E | Front Leg (Left) |  | 1 pce |
| F | Front Stretcher (Short) |  | 1 pce |
| G | Side Stretcher (L/R-Long) |  | 2 pcs |

HARDWARE LIST:

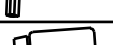
| NO | DESCRIPTION | SIZE | SKETCH | QTY |
|----|-------------------|---------------|---|--------|
| 1 | Pan Head Screw | 8 x 1 1/4" |  | 6 pcs |
| 2 | JCBC Bolt (Short) | M6 x 40mm |  | 2 pcs |
| 3 | JCBC Bolt (Long) | M6 x 70mm |  | 8 pcs |
| 4 | Lock Washer | M6 x 13mm |  | 10 pcs |
| 5 | Flat Washer | M6.5 x 16.5mm |  | 10 pcs |
| 6 | Allen Key | M4 x 2 1/2" |  | 1 pce |
| 7 | Assembly Glue | 10g |  | 1 pce |

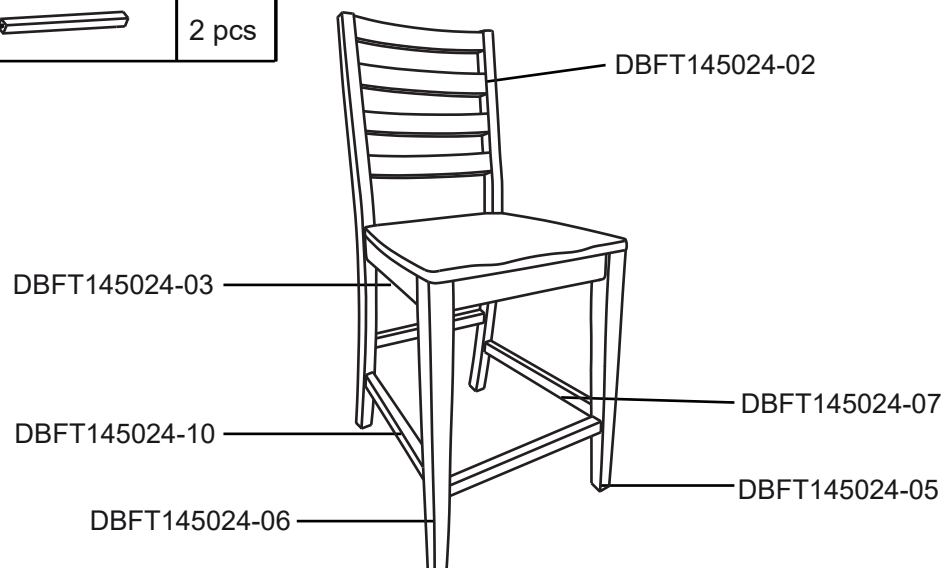

WINNERS ONLY

Assembly Instructions

ASSEMBLY :

DBFT145024

STEP 1

1. Position the chair back on a soft surface such as a carpet. Place the box system assembly (Wood Seat is pre-attached to the seat frame in assembly) on to the middle rail of the chair back with the dowel fully inserted into the pre-drilled hole.
 - 1.1. Insert **JCBC Bolt (Long)** through a **Lock Washer** and a **Flat Washer** into the pre-drilled holes on the apron frame at rear corners.
 - 1.2. Insert the **JCBC Bolt (Short)** through a **Lock Washer** and a **Flat Washer** into the pre-drilled holes on the apron frame at rear rail.

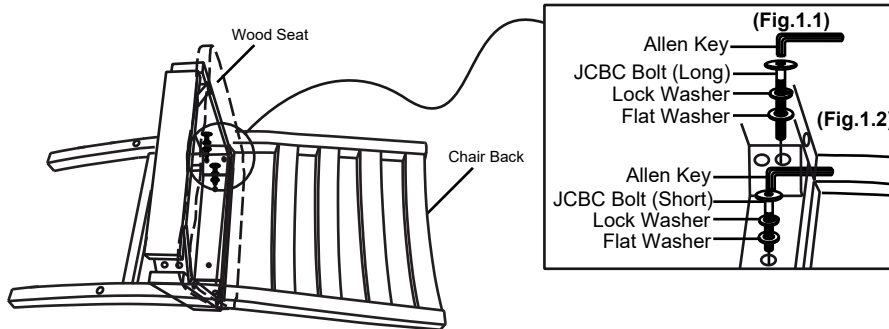

STEP 2

2. Apply **Glue** to all the pre-drilled holes before attaching all stretchers. Insert each side stretcher into pre-drilled holes on both of the rear legs, make sure that screw holes on the stretcher are facing down. Insert the front stretcher into the pre-drilled holes on the front legs. Place the assembled front legs to corner block of the frame, and insert side stretcher into the legs.
 - 2.1. Insert the **JCBC Bolt (Long)** through a **Lock Washer**, a **Flat Washer** and the pre-drilled holes of corner block into the pre-drilled holes on the front leg, tighten the **JCBC Bolt** with **Allen Key** provided. But do not fully tighten the bolts yet.
 - 2.2. Insert **Pan Head Screw** into front stretcher and side stretcher through the pre-drilled holes, tighten with screw driver. (Not Provided)

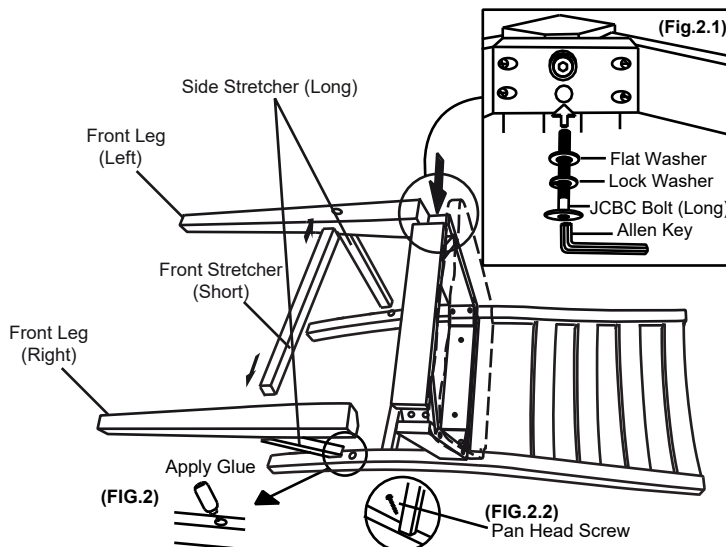

STEP 3

Turn the chair upright. Check its balance and tighten all screws and bolts to complete the assembly.

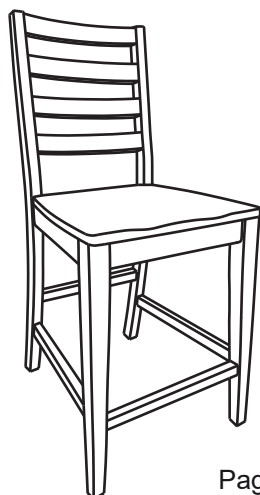

Assembly is now Completed.

CARE INSTRUCTION

- ~ Be sure to use the same type of polish consistently. Your furniture will appear cloudy or streaky if oil based or wax based polishes are interchanged.
- ~ Spray your furniture surface evenly. Wipe in a circular motion with a soft clean cloth.