

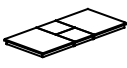



# WINNERS ONLY® Assembly Instructions

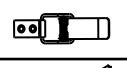

## DRT23678T / DRT23678B

Thank you for purchasing this quality product. Be sure to check all packaging material carefully for small parts that may have come loose inside the carton during shipment.





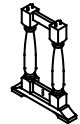

### COMPONENT LIST: DRT23678T

PART NO	FIGURE	DESCRIPTION	QTY
DRT23678T/B-01		Hardware Bag	1 pce
DRT23678T-13		Table Top	1 pce
DRT23678T-02		Apron Hinge	4 pcs
DRT23678T-09		Leaf Hinge	3 pcs
DRT23678T-10		Clamp Lock	4 pcs
DRT23678T-21		Trestle Bar	1 pce
DRT23678T-18		Mounting Plate	2 pcs

### COMPONENT LIST: DRT23678B

PART NO	FIGURE	DESCRIPTION	QTY
DRT23678B-15		Trestle Base	2 pcs
DRT23678B-22		Adjustable Leveler	4 pcs

### HARDWARE LIST1#:

PART NO	FIGURE	DESCRIPTION	QTY
1		Hex Nut	8pcs
2		Lock Washer	20pcs
3		Flat Washer	20pcs
4		Wrench	1 pc
5		JCBB Bolt	12pcs
6		Allen Key	1 pc

### HARDWARE LIST2#:

PART NO	FIGURE	DESCRIPTION	QTY
1		Wood Plug	4pcs

This product will take 15-20 minutes to assemble.

#### Reminders

1. Use only the hardware supplied.
2. Once the product is assembled, level and tighten all the bolts.
3. Do not over-tighten bolts.
4. This item may require periodic tightening

#### NOTE:

1. Two or more people are needed for assembly
2. Please keep all hardware parts out of the reach of children.

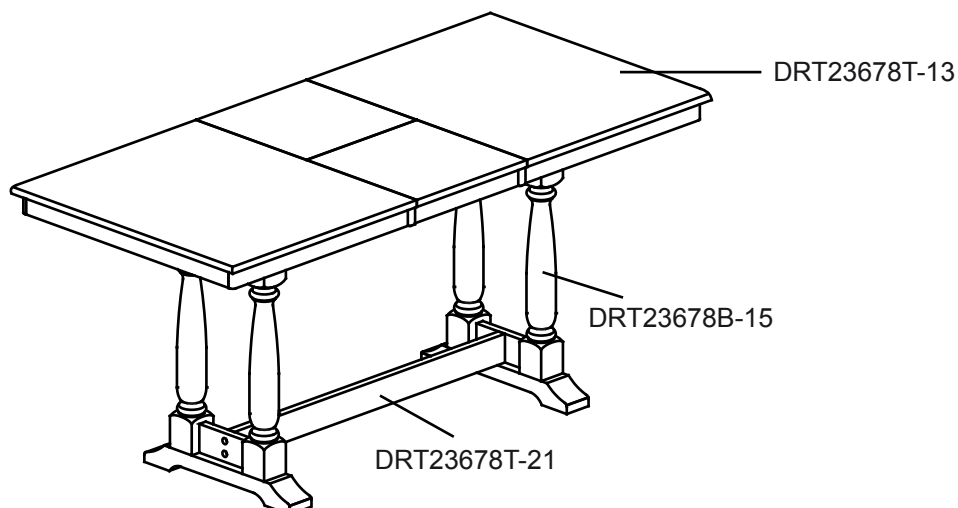

# WINNERS ONLY® Assembly Instructions

DRT23678T / DRT23678B

## ASSEMBLY :

### STEP 1

1.1- Step 1.1 Attach the Leg Stretcher to the Trestle Base using the supplied hardware as shown.

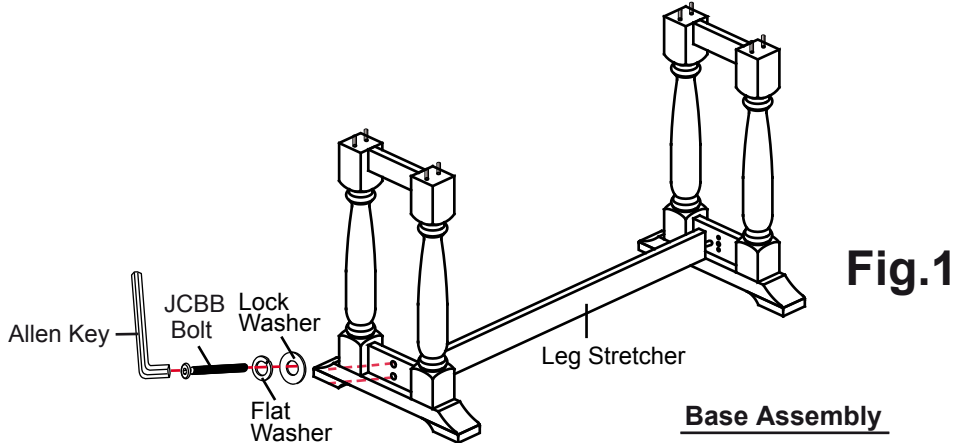

### STEP 2

2.1- Attached Mounting Plate to the Base Assembly by using the supplied hardware as shown on Fig.2

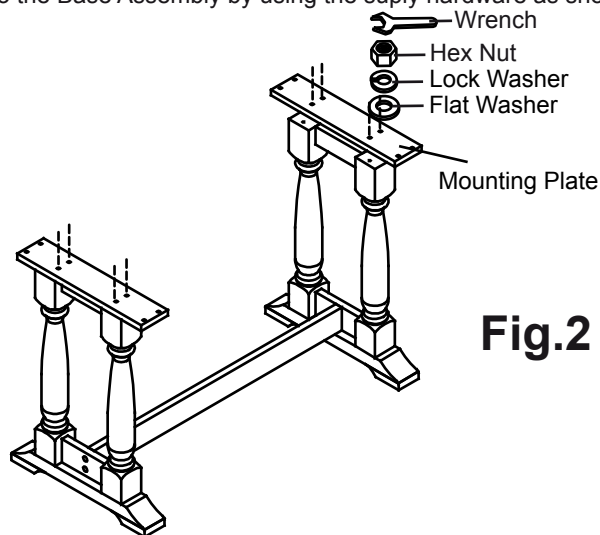

### STEP 3

3.1- Place the Table Top upside down on a soft Protective surface such as a carpet. Remove cleats as shown on Fig 2 .

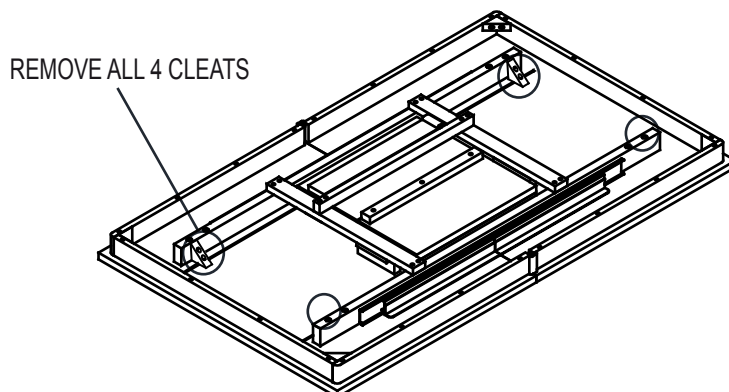

# WINNERS ONLY® Assembly Instructions

DRT23678T / DRT23678B

## ASSEMBLY :

### STEP 4

3.1-Turn Table Top upside down on a soft protective surface such as carpet. Attached Base Assembly to the Table Top by using the supply hardware as shown on Fig.3

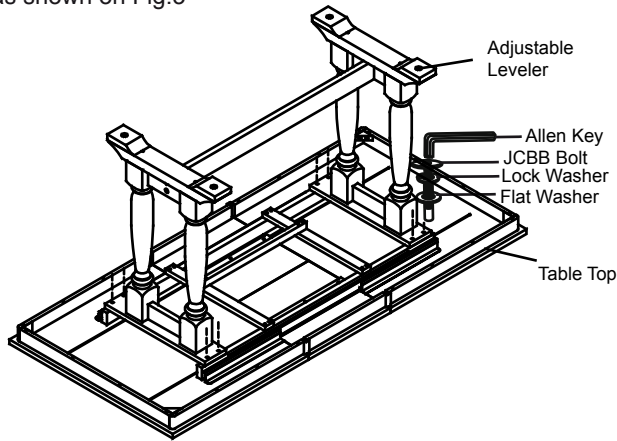
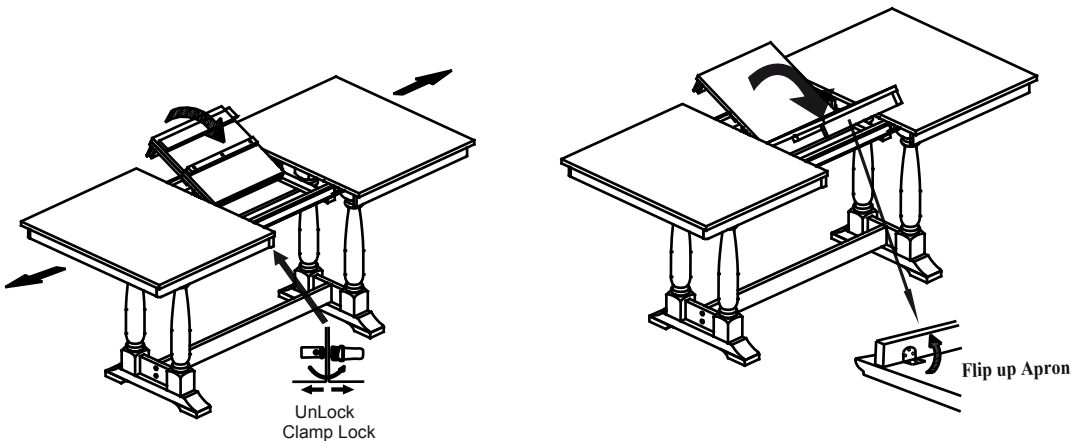

Fig.4

### STEP 5

- 4.1-Unlock the hook lock from underneath the table top and pull the table from both ends.
- 4.2-Lift both leaves from the compartment.
- 4.3-Flip up the aprons and unfold leaf and place the leaf on the Table Top surface carefully.



### STEP 6

- 5.1-Push Table Top from both ends to close. Lock the hooks underneath the table.
- 5.2-Cover the holes located in the left and right table assembly with the wood Plugs provided.

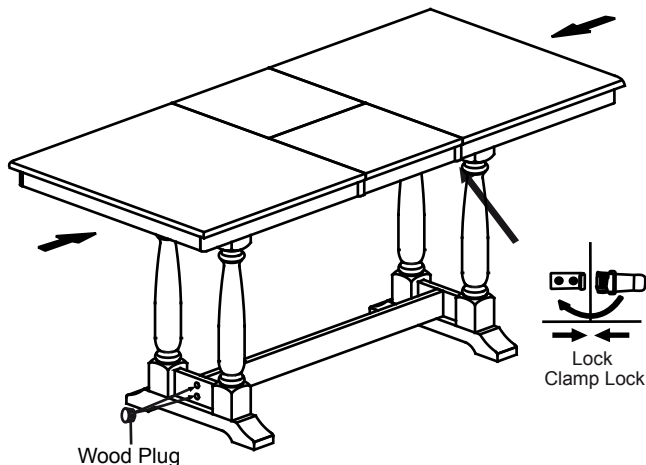

Assembly is now Completed.

#### CARE INSTRUCTION

- ~ Be sure to use the same type of polish consistently. Your furniture will appear cloudy or streaky if oil based or wax based polishes are interchanged.
- ~ Spray your furniture surface evenly. Wipe in a circular motion with a soft clean cloth.