

WINNERS ONLY®

ASSEMBLY INSTRUCTION

PROD.NO : DST345124

Thank you for purchasing this quality product. Please read the instructions thoroughly before unpacking the assembly parts.



Caution:Sharp, exposed staple tips can cause injury, therefore, for your protection, please remove any exposed staples used in packing.

Please keep all hardware parts out of the reach of children.





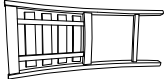
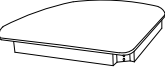

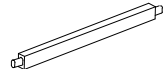
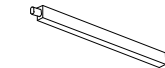
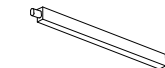
1. We recommend that you should assemble this product with the assistance of another person; this will make assembly easier, and will help to eliminate damage to the product or injury to person during assembly.
2. Hardware pack is located underneath the Cushion Seat (B). Before beginning, please check the packing materials carefully for small parts which may have come loose inside the carton during shipping. Please do not discard any packing material until all parts have been located. If any parts are missing, please contact your dealer for prompt replacement.
3. To prevent damage to your floor or carpet, please check the bottom of each piece of furniture for stain residues and rough surfaces and also check for staples or nails left after removing the packing materials. The manufacturer will not be held responsible if preventive steps are not taken prior to installation.
4. Please do not over tighten screws or bolts. During normal use everyday, screws, bolts, nuts, and wooden plugs may loosen up. They should be periodically inspected and re-tightened to prevent damage to the furniture and (or) personal property or cause injury. Always check to be sure all hardware on this list and the below mentioned components are attached to the furniture properly and kept tightened.
5. Please lay all parts and hardware on a non abrasive surface such as a carpet, and follow the assembly.

This product will take 15 - 20 minutes to assemble

Components List

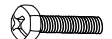
NO	DESCRIPTION	SKETCH	QTY
A	Chair Back		1 pc
B	Cushion Seat		1 pc
C	Front Leg (L)		1 pc
D	Front Leg (R)		1 pc
E	Front Stretcher		1 pc
F	Side Stretcher (R)		1 pc
G	Side Stretcher (L)		1 pc

Hardware List :

NO	DESCRIPTION	SIZE	SKETCH	QTY
1	Hexagon Bolt	M6 x 80 mm		4 pcs
2	Hexagon Bolt	M6 x 60 mm		4 pcs
3	Hexagon Bolt	M6 x 40 mm		2 pcs
4	Spring Washer	1/4" mm		10 pcs
5	Flat Washer	1/4" x 18 mm		10 pcs
6	Spanner @ wrench	10 mm		1 pc
7	PHRS Screw	8 x 1 1/2"		6 pcs

TIP: store the Allen key and or Wrench used in assembly in this product's drawer or use masking or painter's tape to affix it to the underside of the product. This will make it easier to find if you want to periodically tighten bolts or disassemble the product.

WINNERS ONLY[®]

ASSEMBLY INSTRUCTION

PROD.NO : DST345124

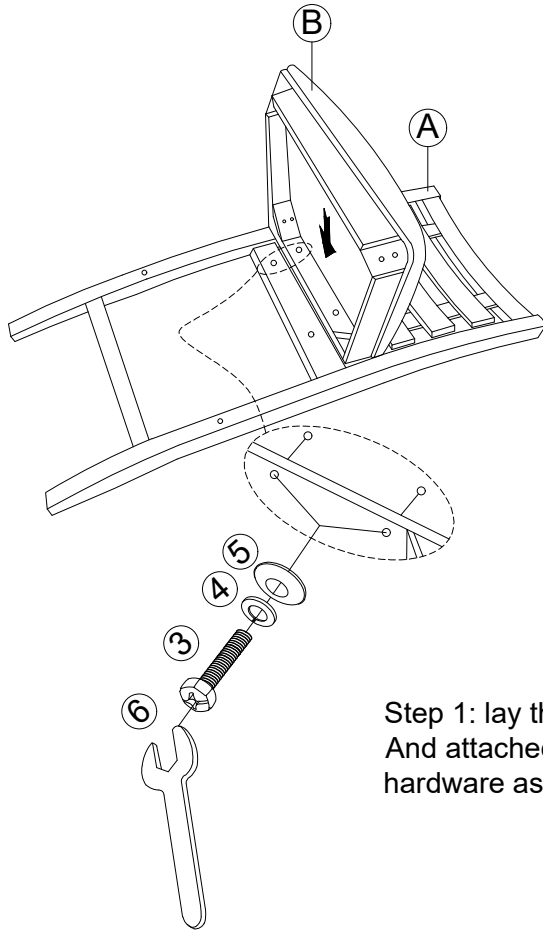

Fig.1

Step 1: lay the Chair Back (A) on a flat Soft surface,
And attached the Cushion Seat (B) using the provided
hardware as shown on Fig.1 And Fig. 2.

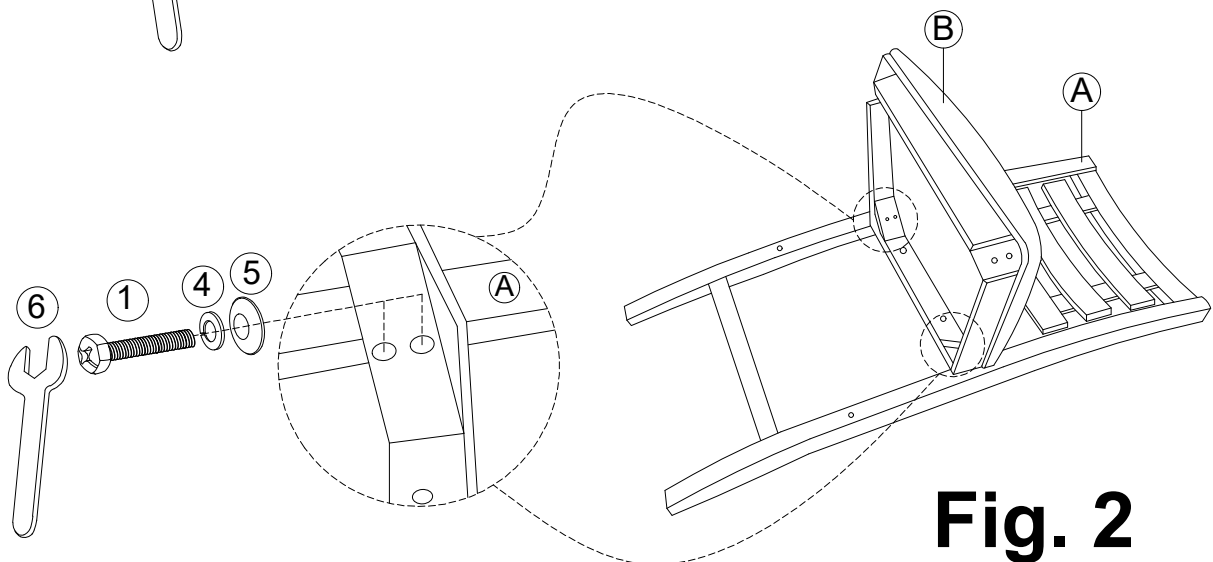

Fig. 2

Note: move seat back
and forward to ease
the finding of the hole in
the corner block.

WINNERS ONLY[®]

ASSEMBLY INSTRUCTION

PROD.NO : DST345124

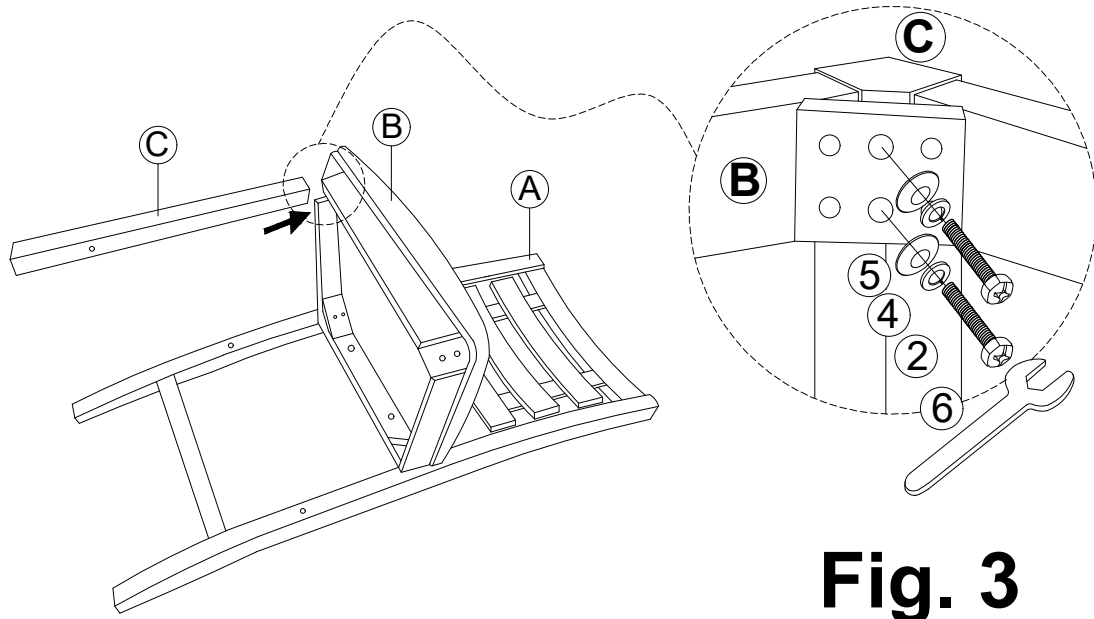

Fig. 3

Step 2: Attach Front legs (C) to Cushion Seat(B) using the provided hardware as shown Fig.3.

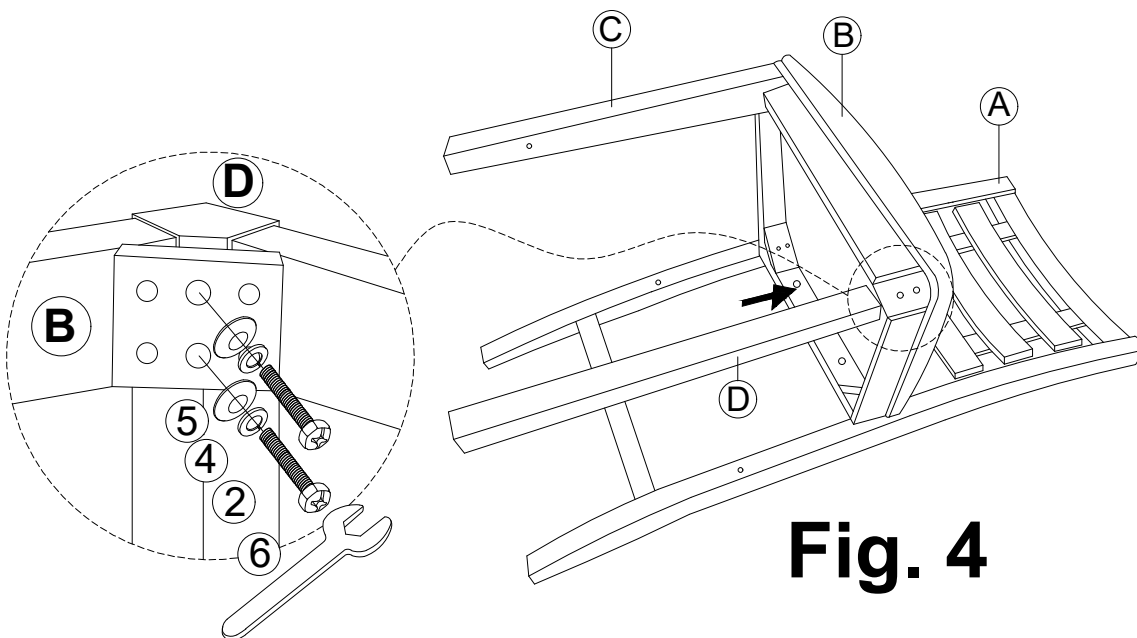

Fig. 4

Step 3: Attach Front legs (D) to Cushion Seat (B) using the provided hardware as shown Fig. 4.

WINNERS ONLY[®]

ASSEMBLY INSTRUCTION

PROD.NO : DST345124

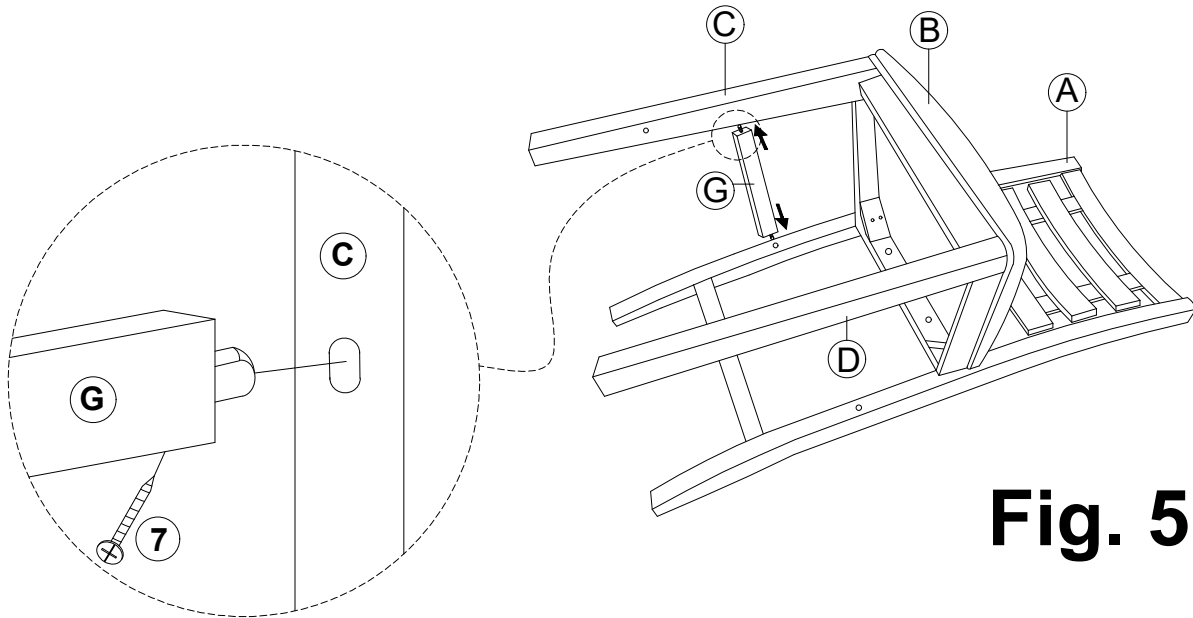

Fig. 5

Step 4: Attach Side Stretcher (G) to Front leg (C) and chair back (A) using the provided hardware as shown Fig.5.

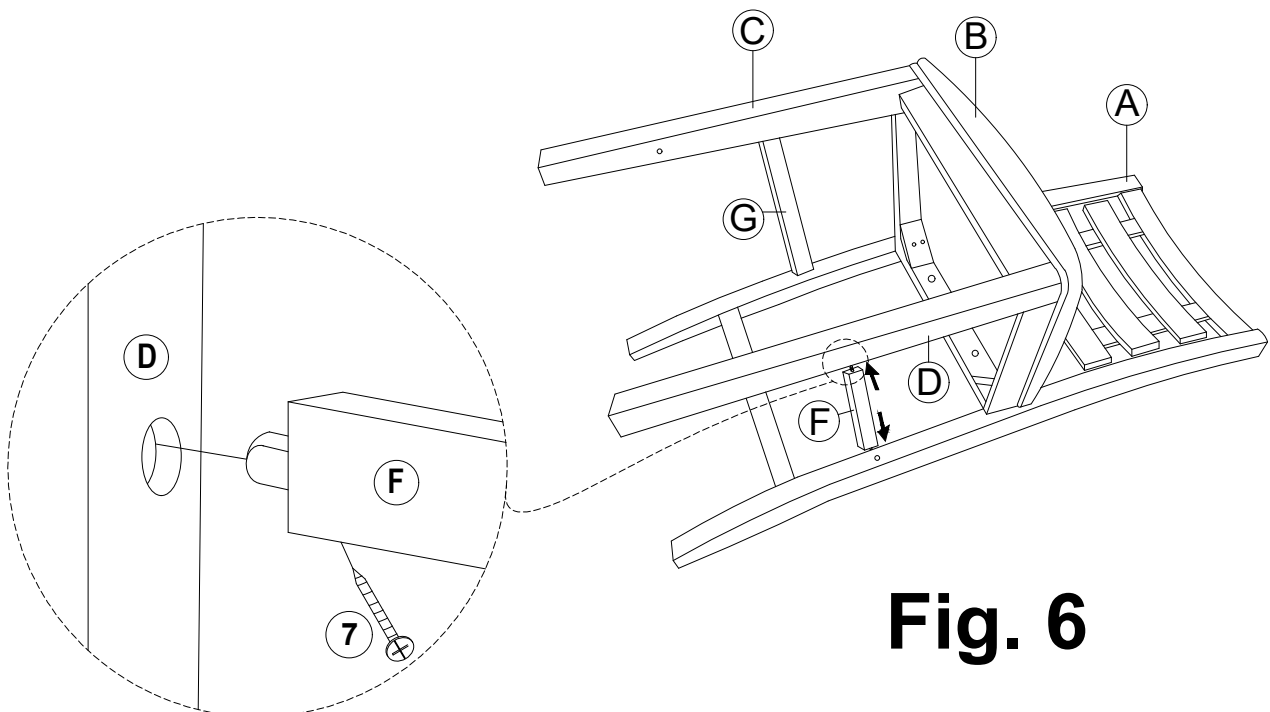

Fig. 6

Step 5: Attach Side Stretcher (F) to Front leg (D) and chair back (A) using the provided hardware as shown Fig.6.

WINNERS ONLY®

ASSEMBLY INSTRUCTION

PROD.NO : DST345124

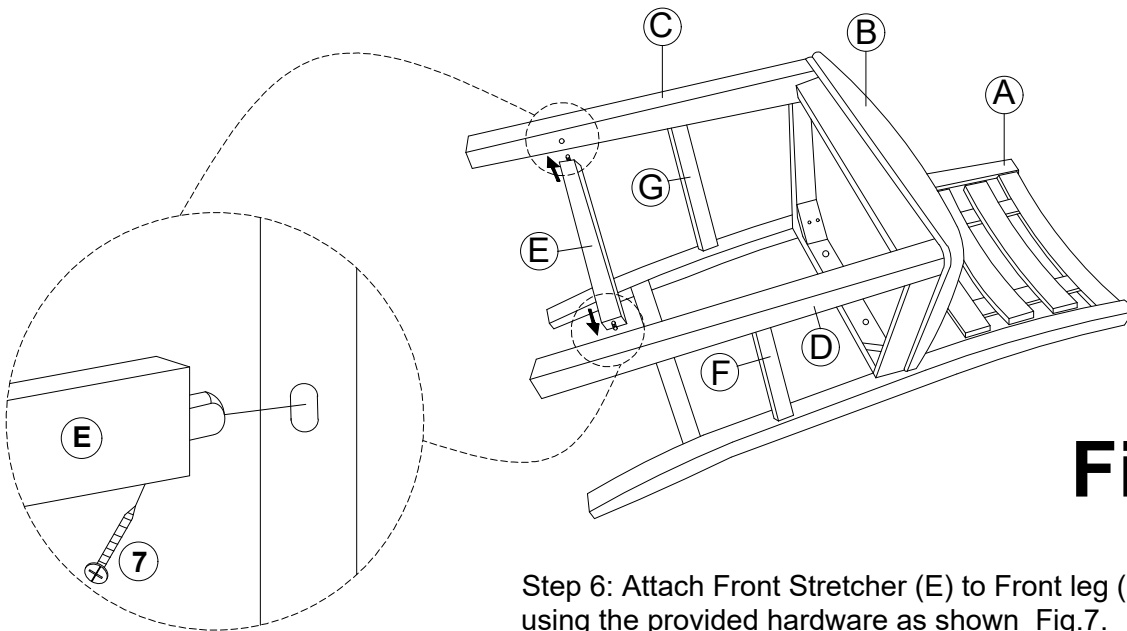

Fig. 7

Step 6: Attach Front Stretcher (E) to Front leg (C) and (D) using the provided hardware as shown Fig.7.

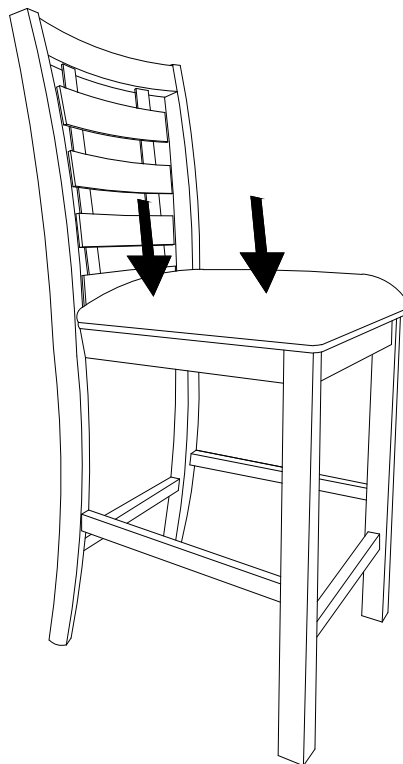

Fig. 8

Step 7: Place the loosely assembled chair on a hard flat surface and apply gentle downward pressure on the seat. As shown on Fig.8. Once the chair is balanced and leveled, fully tighten all bolts.

Assembly is now Complete

IMPORTANT NOTE :

- Please do not overtighten screws or bolts.
- Please keep all hardware parts out of the reach of children.
- Two or more people are needed for assembly.