

WINNERS

ONLY INC.







ASSEMBLY INSTRUCTIONS

ITEM NO : DZH450S







Thank you for purchasing this quality product . Be sure to check all packaging material carefully for small parts that may have come loose inside the carton during shipment .

"Hardware is attached underneath the seat bottom"

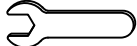
Components List :

A. Back Frame		1pc
B. Seat Frame		1pc
C. Front Leg (Left)		1pc
D. Front Leg (Right)		1pc
E. Side rail (Left)		1pc
F. Side rail (Right)		1pc

Hardware List :

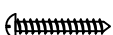
1. Wrench 12x75mm		1pc
2. Allen Key 4x58mm		1pc
3. Bolt 1/4"x38mm		3pcs
4. Bolt 1/4"x85mm		4pcs
5. Hex-Nut 5/16"		4pcs
6. Spring Washer $\phi 13 \times 5/16$ "		11pcs
7. Flat Washer $\phi 19 \times 5/16$ "		11pcs
8. Wood Screw $\phi 8 \times 50$ mm		4pcs

Reminders

1. Use only the hardware supplied.
2. Once the chair is finished, level and tighten all the bolts.
3. Do not over-tighten bolts.
4. This item may require periodic tightening.

NOTE : Hardware pack is located underneath the seat frame (B)

Step1: Attach the seat frame (B) to Back frame (A) by using flat washer (7), spring washer (6) and bolt (3&4).

Step2: Attach Left and Right Side Rails (E&F) to Back frame(A) using Wood Screws (8) through pre-drilled holes of Side Rails (E&F) and Back frame (A). Attach the assembled Front Leg (C&D) to Seat Frame (B) by using flat washers(7), spring washers (6) and hex-nut(5). Attach Front Legs (C&D) to the Left and Right Side Rails (E&F) using Wood Screws (8) through pre-drilled holes on the Left and Right Side Rails (E&F).

Assembly is now complete

Thank you for choosing this product.

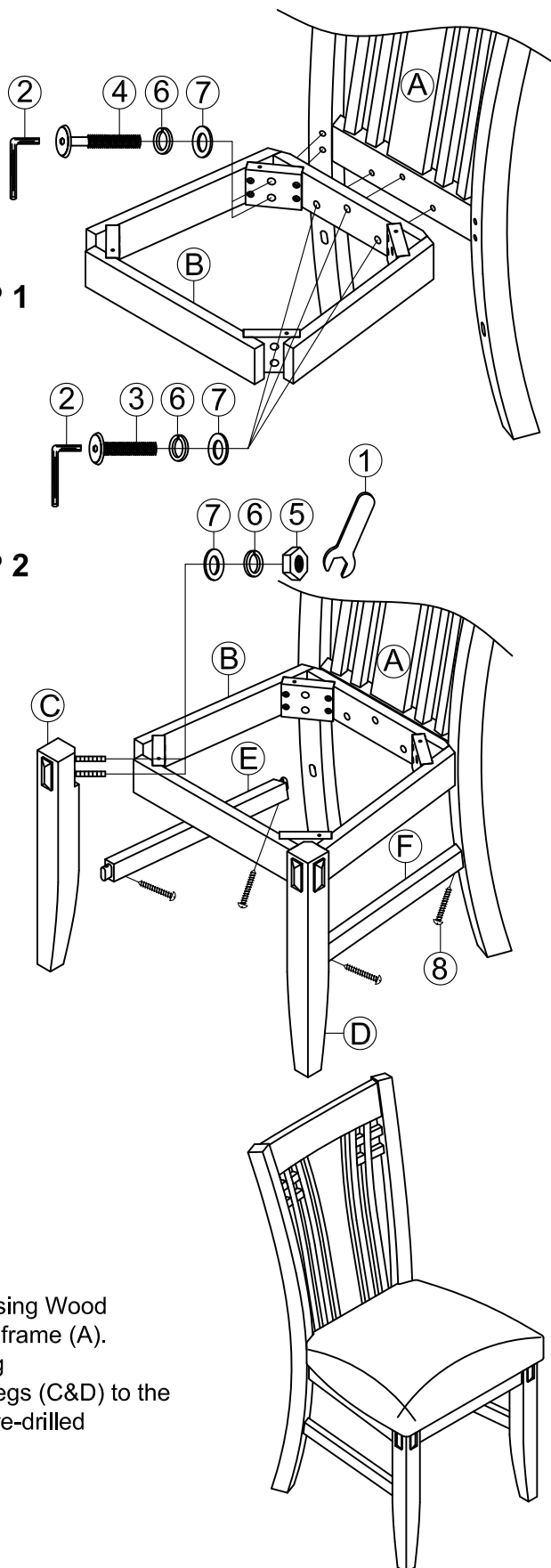

MADE IN VIETNAM